

THIS DOCUMENT CONTAINS DATA PROPRIETARY TO PROJECTS UNLIMITED, INC. ANY USE OR REPRODUCTION, IN ANY FORM, WITHOUT PRIOR WRITTEN PERMISSION OF PROJECTS UNLIMITED, INC. IS PROHIBITED.
 © 2005, Projects Unlimited Inc.

SPECIFICATIONS

| PARAMETERS | VALUES | UNITS |
|------------------------------|------------|-------|
| DIRECTIVITY | OMNI | - |
| SENSITIVITY | -44±3 | dB |
| STANDARD OPERATING VOLTAGE | 2 | Vdc |
| MAX OPERATING VOLTAGE | 10 | Vdc |
| CURRENT CONSUMPTION (MAX) | 0.5 | mA |
| IMPEDANCE | 2.2 | kOhm |
| SIGNAL TO NOISE RATIO (MIN.) | 60 | dB |
| TERMINAL | SOLDER PAD | - |
| INTERNAL CAPACITOR | 33 | pF |

| REVISIONS | | | |
|-----------|---------------------------|--------|----------|
| LTR | DESCRIPTION | DATE | APPROVED |
| - | RELEASED FROM ENGINEERING | 5/3/06 | |
| A | ADDED TERMINAL POLARITY | 2/1/07 | D.F. |

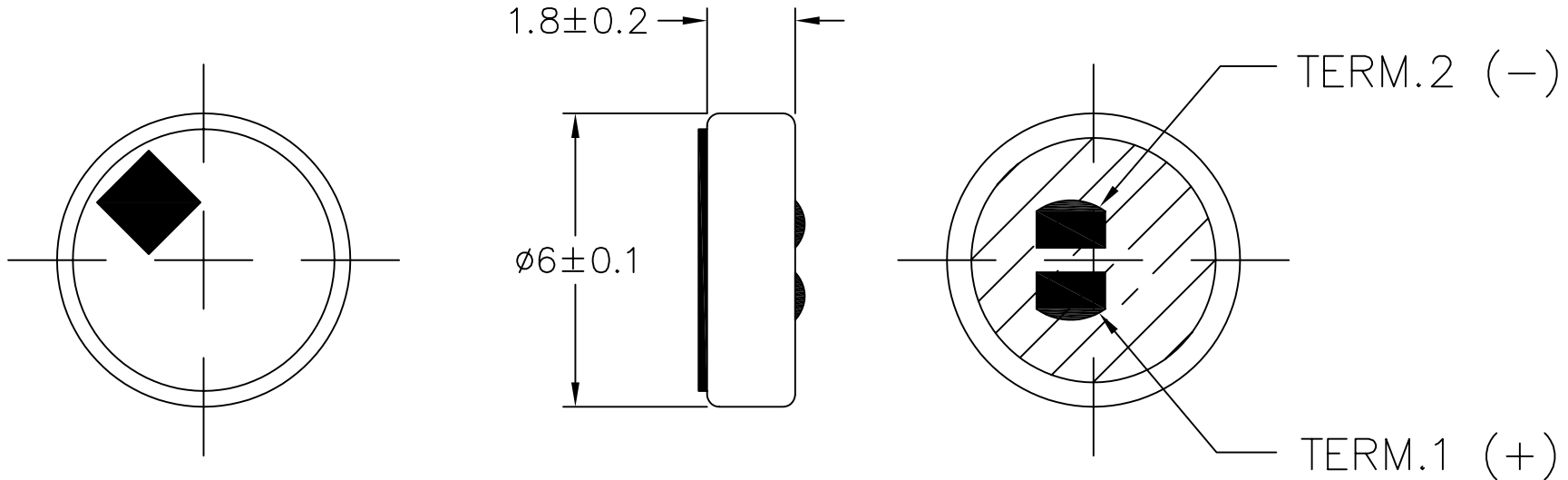

NOTES:

1. ALL DIMENSIONS ARE IN MILLIMETERS.
2. SPECIFICATION SUBJECT TO CHANGE OR WITHDRAWAL WITHOUT NOTICE.
3. THIS PRODUCT IS RoHS 2002/95/EC COMPLIANT.
4. MICROPHONE CLOTH OVER FACE IS IP51 RATED.

FILE NAME
 POM-1844L-C33-R.DWG

| UNLESS OTHERWISE SPECIFIED: DIMENSIONS ARE IN MILLIMETERS, TOLERANCES ARE ± 0.5 AND ANGLES ARE $\pm 3^\circ$. | | projects® unlimited Dayton, Ohio | | | | | | | | | |
|--|--------------------------------|--|--------------|-------------------|------|---------------------|------|----------------------|------|------------|--|
| <table border="1"> <thead> <tr> <th>APPROVALS</th> <th>DATE</th> </tr> </thead> <tbody> <tr> <td>DRAWN <i>J.D.</i></td> <td>5/06</td> </tr> <tr> <td>CHECKED <i>E.P.</i></td> <td>5/06</td> </tr> <tr> <td>APPROVED <i>B.R.</i></td> <td>5/06</td> </tr> </tbody> </table> | | APPROVALS | DATE | DRAWN <i>J.D.</i> | 5/06 | CHECKED <i>E.P.</i> | 5/06 | APPROVED <i>B.R.</i> | 5/06 | MICROPHONE | |
| APPROVALS | DATE | | | | | | | | | | |
| DRAWN <i>J.D.</i> | 5/06 | | | | | | | | | | |
| CHECKED <i>E.P.</i> | 5/06 | | | | | | | | | | |
| APPROVED <i>B.R.</i> | 5/06 | | | | | | | | | | |
| SIZE A | DRAWING NO. POM-1844L-C33-R | | | | | | | | | | |
| DO NOT SCALE DRAWING | | SCALE: N.T.S. | SHEET 1 OF 1 | | | | | | | | |